

Standard Type B curb

WHERE T IS EQUAL TO PAVEMENT THICKNESS OR 6", WHICHEVER IS GREATER

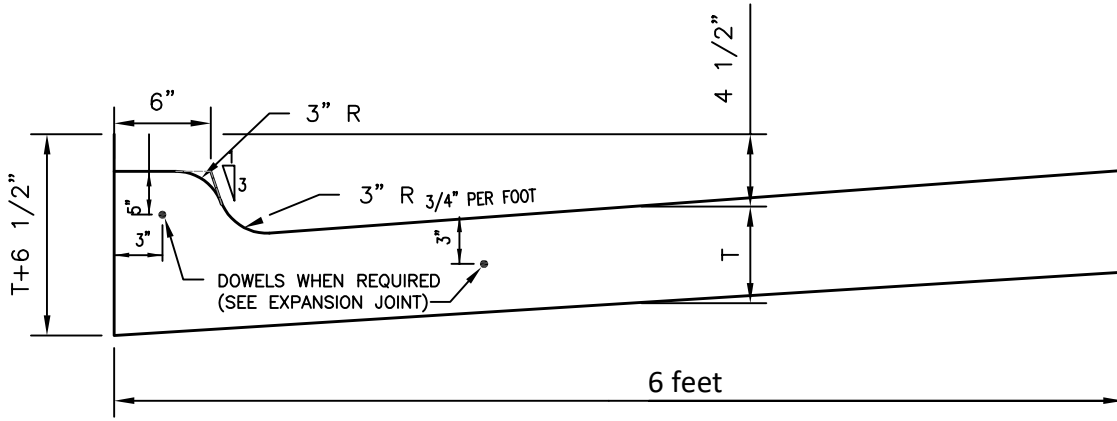

Standard Type B curb with Bike Lane width

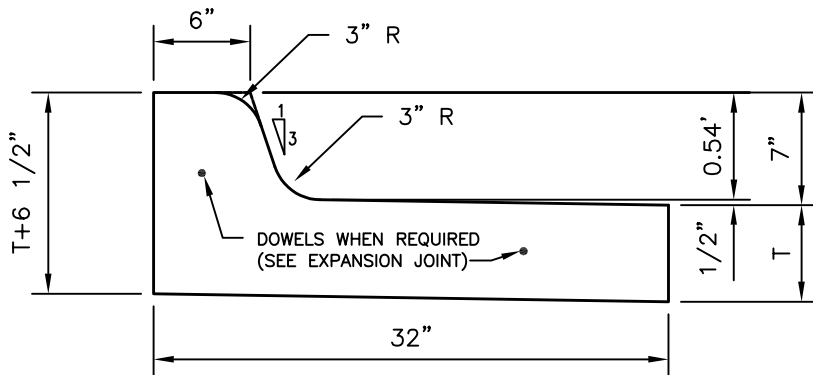

TILTED CURB & GUTTER (TYPE BL)

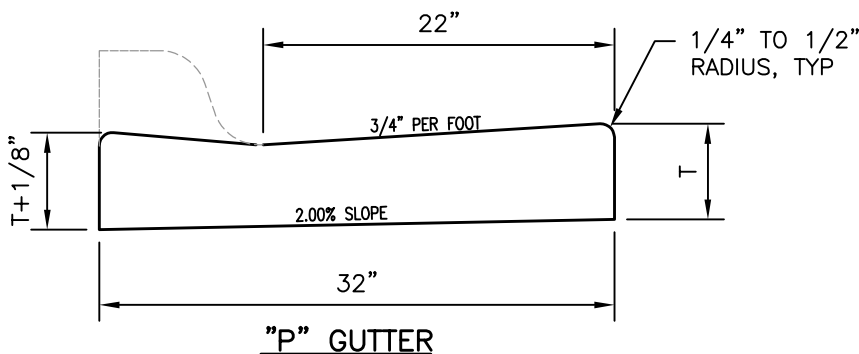

"P" GUTTER

NOTES:

ALL CURB & GUTTER SHALL HAVE A 28 DAY COMPRESSIVE STRENGTH OF NOT LESS THAN 4000 P.S.I. & AIR ENTRAINED 6% ± 1.5% (4.5% TO 7.5%). ALL DESIGN GRADES ARE TOP OF CURB ELEVATIONS UNLESS OTHERWISE INDICATED ON PLANS. EXPANSION JOINT FILLER IS TO BE PLACED IN THE CURB & GUTTER AT EACH JUNCTION OF A RADIUS. IT SHALL BE PLACED AS PER DETAIL 5-8. TRANSVERSE EXPANSION JOINT OR CONTRACTION JOINTS SHALL BE PLACED IN THE CURB & GUTTER AT 15' MAXIMUM INTERVALS OR MATCH JOINTS OF CONCRETE PAVEMENT. DOWELS WHEN REQUIRED SHALL BE #5 SMOOTH EPOXY COATED.

MINIMUM DEPTH OF GRANULAR MATERIAL PLACED UNDER CURB & GUTTER SHALL BE 4".